



C73LSE

Video balancing machine with pneumatic locking
Video balanserka sa pneumatskom flansom



VDD

Virtual Direct Drive
(CEMB patent)

TFT

17" Flat Screen

Options

LA

Width measuring sonar

EMS

Wheel eccentricity

Zero weight

Automatic lift

CEMB C73

VDD
Virtual Direct Drive



C73LSE

Dedicated to operators looking for a quick, accurate, simple and reliable video balancing machine

GENERAL FEATURES

- **VDD** very quick and maintenance free measurement system (**Cemb Patent**)
- 17" TFT Flat Screen
- **IC concept**, reduction of residual vibrations on the vehicle
- Autodiagnosis and self-calibration
- Selection menu for options and customizations
- Intelligent and automatic system to measure diameter and distance with the Cemb gauge
- **Electromagnetic brake** to lock the wheel in the correction position
- **Locking** of the measuring gauge in the correction position for **ALU** wheels (**Cemb Patent**)

- **SPLIT** program to hide weights behind spokes



- **ALU-S** balancing mode (adhesive weights on the internal rim planes) with specific counterweight position indicator (position repeater)



- **Eccentricity measurement** with sonar (1st Harmonic and Peak to Peak) Automatic and quick eccentricity measurement during the normal balancing cycle



RPR Function:

Real Plane Residual Unbalance

- In ALU-S balancing mode (adhesive weights on the internal rim planes) the residual unbalance is displayed with reference to the external rim planes (according to wheel/car manufacturers the balancing tolerance is to be referred to the external rim planes)
- Any unnecessary correction operation is avoided



- **Pneumatic wheel locking (Cemb Patent)**
 - Mounting/demounting time reduction
 - Extremely easy and quick to use
 - Accurate wheel centering guaranteed
 - Possibility to use traditional adapters (UH20)



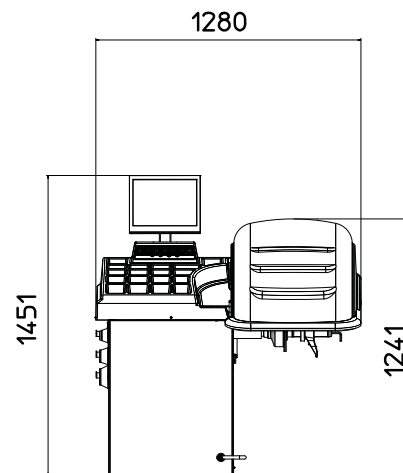
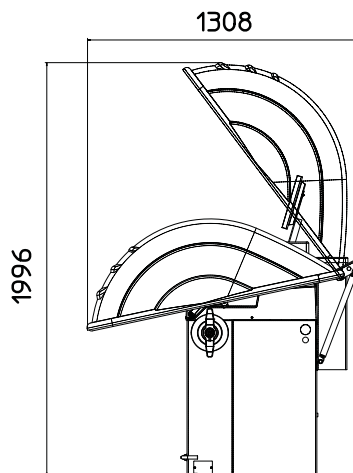

Single phase power supply	115/230 V 50/60 Hz
Absorbed power	0,15 kW
Balancing speed	100 rpm
Measuring cycle for wheel 15 kg	4.7 s (5 3/4" x 14")
Measurement uncertainty	0,5 g (0.04 oz)
Average noise	< 70 dB (A)
Rim width setting range	40 ÷ 510 mm (1.5" ÷ 20")
Rim diameter setting range	265 ÷ 765 mm (10" ÷ 30")
Min/max compressed air	8 ÷ 10 kg/cm ² ~ 0.8 ÷ 1 Mpa ~ 8 ÷ 10 bar ~ 115 ÷ 145 psi
Max. wheel weight	< 75 kg
Machine weight	C73L 130 kg (287 lbs) - C73LSE 150 kg (331 lbs)
Packaging	113x102x173h cm (45"x40"x68"h)

Also available
with manual locking

STANDARD ACCESSORIES

In 1952 Cemb created the cone adapters for balancing machines and since then the company continued developing and producing high precision centering systems for any type of wheel. **Cemb does not recommend the use of non-original adapters on its balancing machines.**

UC20/SE2 41FF52768



Pneumatic locking

Standard equipment composed of: 3 cones Ø 45 ÷ 110 mm, quick locking sleeve SE2, width gauge, pincer-hammer and 60 g counterweight



UC20/2 GL40 41FF83149



Manual locking

Standard equipment composed of: 3 cones Ø 45 ÷ 110 mm, quick locknut GL40, width gauge, pincer-hammer and 60 g counterweight



OPTIONAL ACCESSORIES Especially designed for car manufacturers



RL cup 41FF79255

Large plastic cup with polyurethane protection ring for light alloy rims.

VL/2 cone + G36 disc 41FF86174

Kit for light truck wheels (Ø97 ÷ 170mm central hole).

MT cone 40FF57321

High precision graduated cone for German cars (with central hole Ø56,5 / 57 / 66,5 / 72,5 mm).

UH20/2 41FF42048

Universal adapter for wheels with 3,4,5,6 holes (pitch circle Ø95-210 mm) complete with high precision back centering double cone for wheels with/without central hole (Renault, Peugeot and Citroën). Grants double accuracy compared to similar adapters on the market.

SR4 - SR4/SE - SR5 - SR5/SE SR5/2 SR5/2/SE - SRUSA - SR/USA/SE

Stud adapters for rim protection and high precision centering for wheels with 4 or 5 holes. Studs are made of two pieces, elastically coupled: pressure is therefore homogeneous on all the holes.

Mercedes kit 41FF88003

High precision kit : 3 cones (Ø57 - Ø66,5 - Ø84/85mm) + 1 pressure spring, according to Mercedes Benz specifications.

Peugeot - Citroën kit 41FF73171

High precision kit: 1 bush Ø60mm + 2 cones (Ø62 ÷ 68 mm and Ø54 ÷ 60 mm). Developed according to Peugeot and Citroën specifications.

Renault kit 41FF77152

High precision kit : 5 bushes (Ø60 / 66 / 71 / 88 / 129,9 mm). Developed according to Renault specifications.

For more information see the complete brochure on the web site www.cemb.com

Option to increase your profitability ZERO WEIGHT Lift

ZERO WEIGHT

Zero gravity effect
Wheel loading and removal without effort or adjustment

PERFECT CENTERING

Wheel automatic lifting
Ideal centering and more accurate balancing

QUICK

Quicker than any other traditional lift
A single pedal controls the whole working cycle

AUTOMATIC

Electronic system with PLC

UNIVERSAL

Applicable to any balancing machine

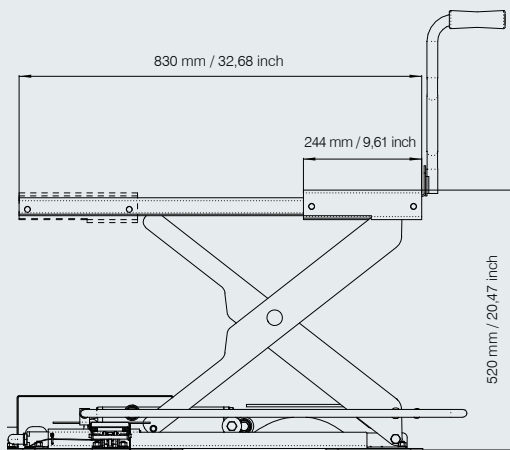

For more information see the complete brochure on the web site www.cemb.com



Some of our customers:

FERRARI • MASERATI • LAMBORGHINI •
MERCEDES-BENZ • BMW • VOLKSWAGEN • FIAT •
LANCIA • ALFA ROMEO • FORD NISSAN • RENAULT
• HARLEY DAVIDSON • HONDA • YAMAHA • SUZUKI
• KAWASAKI • KTM • DUCATI • TRIUMPH • APRILIA -
PIAGGIO • MOTO GUZZI • PIRELLI • BRIDGESTONE
• MICHELIN • CONTINENTAL • DUNLOP •
GOODYEAR • BREMBO • METZELER



CEMB

BALANCING MACHINES



CEMB S.p.A.

Via Risorgimento, 9
23826 Mandello del Lario (LC) Italy
www.cemb.com



Garage equipment division

CEMB - ITALY

Plant and Training Center

phone +39 0341 706369
fax +39 0341 700725
garage@cemb.com

CEMB USA

BL Systems Inc.

2873 Ramsey Road
Gainesville, GA 30501 - USA
Phone +001 678 717 1050
Fax +001 678 717 1056
sales@cemb-usa.com

Cemb technology



ITALIAN HEART: All parts which influence the quality of our balancers are manufactured within Cemb through appropriate machinery. The tolerances used are the most accurate on the market. Only in this way it is possible to maintain a constant and accurate balancing through time.

VDD - New: Defined as a "Maintenance Free" concept, it allows maximum accuracy in minimum time, increasing reliability and features of all Cemb balancers. This has been possible thanks to a new patented system of measurement (both mechanical and electronic) as a result of Cemb's unique experience in the field of industrial balancing and vibration analysis instrumentation. With the VDD even the most economic Cemb balancer wins against any of its competitors in both speed and accuracy.



CEMB FOR THE ENVIRONMENT

Our machines save much more energy than you would think! We care for the environment, as much as we care for your costs: these are our priorities. Save money! Save the environment!
Buy our machines.

Ask for more details, we are at your full disposal.



Balanserke - Rakocevic

All the data and features mentioned in this catalogue are purely for information and do not constitute any commitment on the part of our company, which reserves the right to make any and all alterations it may consider suitable without notice.