



DWA1000

8-CCD wheel Alignment

Uredjaj za reglazu trapa sa 8 CCD senzora



Li⁺

Lithium Powered

BT²

BT² Communication



Featherweight Sensors



DWA1000

Dedicated to car and light truck operators looking for a quick, accurate, simple and reliable wheel alignment



Lithium batteries:
FORGET YOU EVEN HAVE THEM

Charge last 24 hours under normal use
1 year guaranteed battery life



Innovative BT² wireless communication:
IMMEDIATE AND OBSTACLE-FREE CONNECTION



Featherweight sensors:
ONLY 2.6 KG



Silicon accelerometer:
SHOCK INSENSITIVE



Designed to fit also SUV tyres:
NO EXTENSIONS REQUIRED



Simple and user-friendly software:
MAKES WORK EASY



Store and recharge sensors together with clamps:
DON'T WASTE TIME DISMANTLING



Truck and bus wheel alignment:
UPGRADE AVAILABLE

Over 12 meters wheelbase even in outdoor sun exposed environment

SOFTWARE



3D Print out

NEW



FAST caster swing



Adjust two axles in one screen



Clear help for adjustment



Direct spoiler no extensions required

Configuration

DWA1000L



DWA1000W



DWA1000Light



With CABINET

Ergonomic design
suitable to all working environments

NO CABINET!

Save your working space
with your laptop

STANDARD CONFIGURATION

OPTIONAL ACCESSORIES

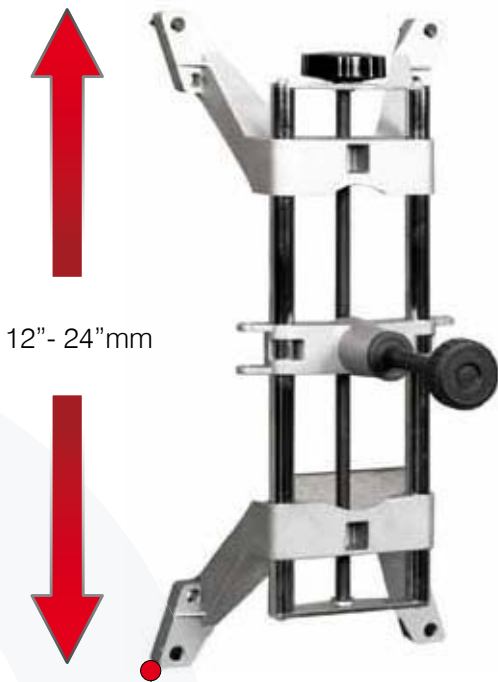

12" - 24" mm



Clamp supporting arms and set of tips for tyres with external diameter up to 31"



Optional up to 40"



Optional up to 30"

45mm
universal grips

48mm
reference surface grips

Grips for all rims and tyres are available



Metal 80 mm
universal grips
for 4-WD, SUV
and light trucks



Metal grips for
clamping on steel
rims from the inside



Metal 48 mm grips
with reference surface
to optimize runout,
rubbered to prevent
scratches on alloy rims

STANDARD CONFIGURATIONS



DWA 1000L



DWA 1000W



DWA 1000W light

DESCRIPTIONS

Computer - 19" monitor - printer



Car & light truck software and database



4 Car sensors



4 Clamps + safety elastic band
+ 2 set of grips



2 Cars turnplates



Steering lock + Brake pedal lock



OPTIONS

TECHNICAL DATA



Truck and Bus
upgrade Kit



Sensors bracket
wall panel



Sensors bracket
trolley

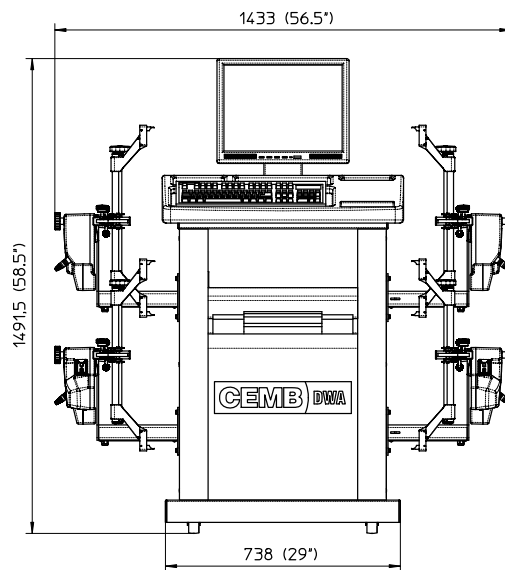

Package dimensions and gross weight:

type1: 120x150x130h cm (220 Kg)
47"x60"x51" (485 pound)
type2: 105x90x150h cm 41"x35"x59"
+ 135x75x115h cm (totale 240 Kg)
53"x29"x45" (total 529 pound)

Net weight: 155 Kg (342 pound)



CEMB

BALANCING MACHINES



CEMB S.p.A.

Via Risorgimento, 9
23826 Mandello del Lario (LC) Italy
www.cemb.com



Garage equipment division

CEMB - ITALY

Plant and Training Center

phone +39 0341 706369

fax +39 0341 700725

garage@cemb.com

CEMB USA

BL Systems Inc.

2873 Ramsey Road

Gainesville, GA 30501 - USA

Phone +001 678 717 1050

Fax +001 678 717 1056

sales@cemb-usa.com

Masina za reglazu i centriranje
trapa - Rakocevic

Cemb technology



ITALIAN HEART: All parts which influence the quality of our machines are manufactured within Cemb through appropriate machinery. The tolerances used are the most accurate on the market. Only in this way it is possible to maintain a constant and accurate balancing through time.

All the data and features mentioned in this catalogue are purely for information and do not constitute any commitment on the part of our company, which reserves the right to make any and all alterations it may consider suitable without notice.